

# Heat Shrinking Teflon Sleeve Instructions for B-65 Collets

- Place the Teflon sleeve around the collet body, covering the slot windows (do not get tubing onto back bearing - see .78" dimensions)
- Use a 750 Watt heat gun on the O.D. of the tubing
- Rotate the collet as heat is applied (Approximately 1 to 2 minutes required)
- Install RTV Sealant in the collet head slots after heat shrink is complete (allow at least 24 hours to cure)

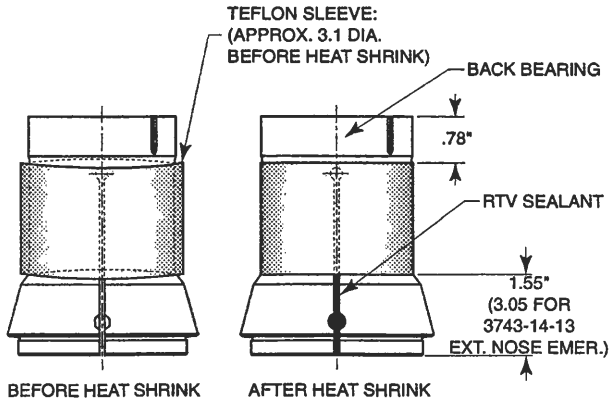

Items	Part Number
Teflon Sleeve	3757-0000000-A19
RTV Sealant	CE-0010884-0832 (Dow Corning #832)